

# Absolute encoders - SSI

## Solid shaft $\varnothing 10$ mm with clamping flange

### Optical singleturn encoders 13 bit ST

#### ATD 2S B14 Y21



ATD 2S B14 Y21 with clamping flange

#### Features

- Encoder singleturn / SSI
- Optical sensing
- Resolution: singleturn 13 bit
- Centering alignment  $\varnothing 36$  mm, mounting screw hole circle  $\varnothing 48$  mm
- Flange socket radial

#### Technical data - electrical ratings

Voltage supply	10...30 VDC
Reverse polarity protection	Yes
Consumption w/o load	$\leq 50$ mA (24 VDC)
Interface	SSI
Function	Singleturn
Steps per turn	8192 / 13 bit
Sensing method	Optical
Code	Gray
Code sequence	CW: ascending values with clockwise sense of rotation; looking at mounting surface
Output stage	SSI data: linedriver RS485
Interference immunity	DIN EN 61000-6-2
Emitted interference	DIN EN 61000-6-3

#### Technical data - mechanical design

Size (flange)	$\varnothing 58$ mm
Shaft type	$\varnothing 10$ mm solid shaft (clamping flange)
Flange	Clamping flange
Protection DIN EN 60529	IP 67 (at shaft entrance)
Operating speed	$\leq 5000$ rpm (mechanical) $\leq 8000$ rpm (electric)
Starting torque	$\leq 0.05$ Nm (+20 °C)
Shaft loading	$\leq 40$ N axial $\leq 60$ N radial
Materials	Housing: aluminium Shaft: stainless steel
Operating temperature	-30...+85 °C
Relative humidity	90 % non-condensing
Resistance	DIN EN 60068-2-6 Vibration 10 g, 55-2000 Hz DIN EN 60068-2-27 Shock 30 g, 11 ms
Weight approx.	350 g
Connection	Connector M16, 7-pin

# Absolute encoders - SSI

Solid shaft ø10 mm with clamping flange  
Optical singleturn encoders 13 bit ST

ATD 2S B14 Y21

## Part number

ATD 2S B14 Y21 **13** **SS** **GR** **D1SR7** **M** **10** **IP65**

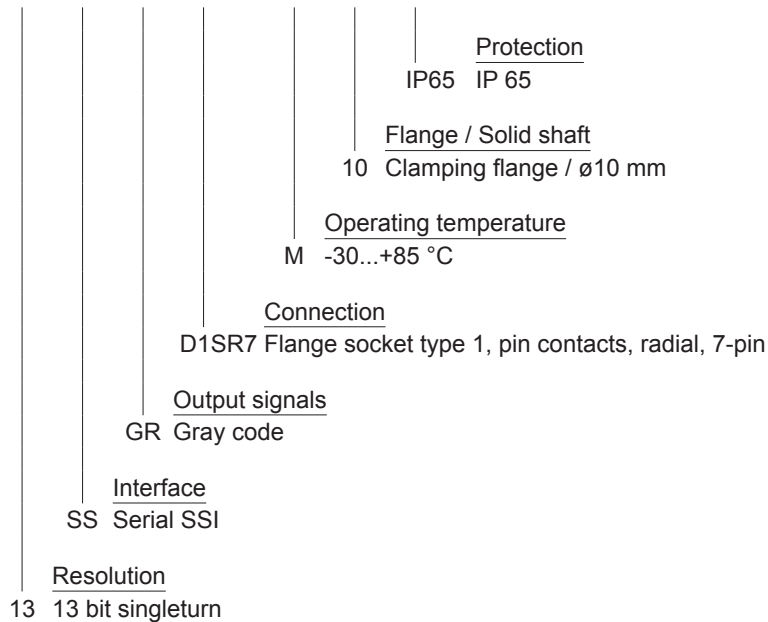

## Data transfer

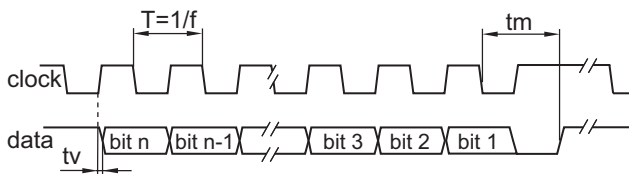

Clock frequency f	80...1000 kHz
Duty cycle of T	40...60 %
Delay time tv	150 ns
Monoflop time tm	20 µs + T/2
Clock interval tp	26 µs

# Absolute encoders - SSI

## Solid shaft $\varnothing 10$ mm with clamping flange

### Optical singleturn encoders 13 bit ST

#### ATD 2S B14 Y21

##### Trigger level

SSI	Circuit
SSI-Clock	Receiver RS485
SSI-Data	Linedriver RS485

##### Terminal significance

UB	Encoder supply voltage.
GND	Encoder ground connection relating to UB.
Data+	Positive, serial data output of differential linedriver.
Data-	Negative, serial data output of differential-linedriver.
Clock+	Positive SSI clock input. Clock+ together with clock- forms a current loop. A current of approx. 7 mA towards clock+ input means logic 1 in positive logic.
Clock-	Negative SSI clock input. Clock- together with clock+ forms a current loop. A current of approx. 7 mA towards clock- input means logic 0 in positive logic.

##### Terminal assignment

Connector	Assignment
Pin 1	GND
Pin 2	data+
Pin 3	data-
Pin 4	clock+
Pin 5	clock-
Pin 6	-
Pin 7	UB

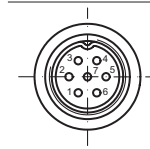

##### Dimensions

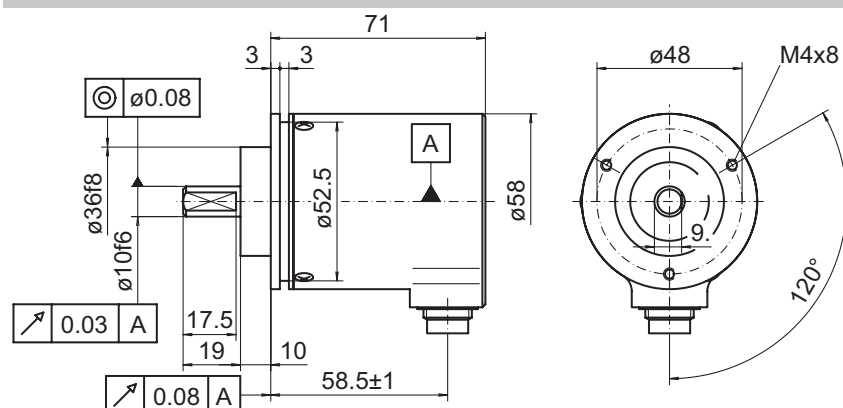

028- 7 Y21

**Absolute encoders - SSI**  
Solid shaft  $\varnothing 10$  mm with clamping flange  
Optical singleturn encoders 13 bit ST

ATD 2S B14 Y21

---